

Description : Pyridine-Picoline-Water Separation System

Process Flow Diagram

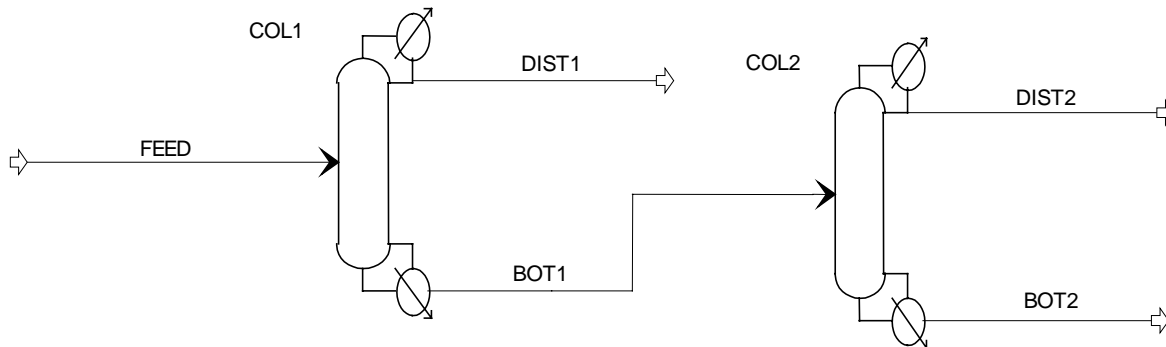

Process Description

A mixture of Pyridine, water and γ -picoline (2-methyl pyridine) is fed to first column. Pyridine-water azeotrope is removed from first column. Bottom stream, containing pyridine and picoline is separated in second column. Pure pyridine is collected as distillate and picoline is collected as bottom.

Water	: 5-10 % (wt)
Pyridine	: 40-45 % (wt)
Picoline	: 40-45% (wt)

Design basis : Pyridine above 99% purity and picoline above 99.5 % Purity

Operating Conditions

Operating Pressure
Both columns are operating under atmospheric pressure
Column Internals :
Structured packing for the column

Experience

Finepac™ Structures Pvt. Ltd. has supplied separating systems involving azeotropic distillation. Pyridine, water and p is typical system involving Pyridine-water azeotrope. Also, very high stages are required for the separation of pyridine and picoline.

